



BASCO[®] **Pipeline Aftercoolers**

Quality, Value and Performance. An API Heat Transfer Tradition.

API has over 75 years of experience designing & building heat exchangers for all types of applications all over the world.

Whenever there is a need for cooling compressed air or gas in your piping system, consider the Basco® Pipeline Aftercooler.

Basco PLAC for Compressed Air Cooling

Basco Pipeline Aftercoolers (PLAC)

The Basco PLAC and PLAC II aftercooler and companion separator provide an ideal combination to remove troublesome moisture from your compressed air or gas. Successful installations of Basco aftercoolers/separators world- wide provide conclusive proof of their effective performance in maintaining trouble-free operation of air powered tools and equipment.

The PLAC design has tubes effectively arranged to maximize heat transfer and reduce cooling water usage. Tubes are readily accessible for cleaning to maintain their high heat transfer efficiency and low pressure drop. Removable tube bundles allow cleaning of shell side surfaces. Fabricated according to ASME code, PLAC's are designed to operate at 150 psi maximum both sides.

Where space limitations for lengths and diameters exist, the Basco standard PLAC II unit is a compact version of the PLAC. It utilizes specially contoured BASCOR 3/8" or 5/8" tubes with enhanced surface for improved heat transfer.

The matching in-line cast iron centrifugal separator has been individually designed and sized for each aftercooler to provide maximum efficiency in removing virtually all moisture over the entire operating range of the aftercooler. All Basco separators are designed to bolt directly to the aftercooler, without the need for spools, to minimize pressure drop & overall unit length.

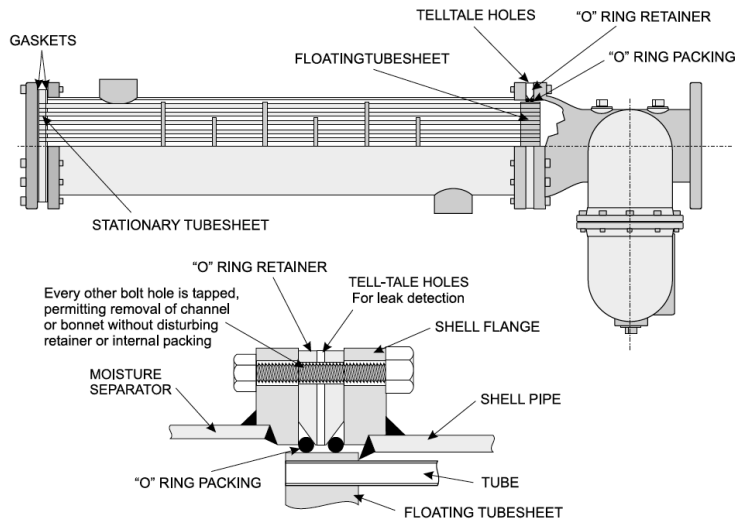

Features

Removable Tube Bundle

Double Packed Floating Tubesheet with O-Rings

Tell-Tale Holes

Shell Sizes from 6" to 16" without spools - separator bolts direct to unit.

Standard Pressure Range is 75 to 150 psi.*

Benefits

Simplifies cleaning of both tubes and shell sides, and reduces future maintenance costs.

Allows for proper thermal expansion caused by temperature differences.

Allows easy visual detection of leaks

Meets virtually all in-line aftercooler requirements & conserves on space.

Standard design meets the majority of material & code requirements.

*Higher pressures are available with a variety of material substitutions.



Basco Centrifugal Separator

Designed for installation with the Basco PLAC aftercooler or for retro fit with other suitable aftercooler units.

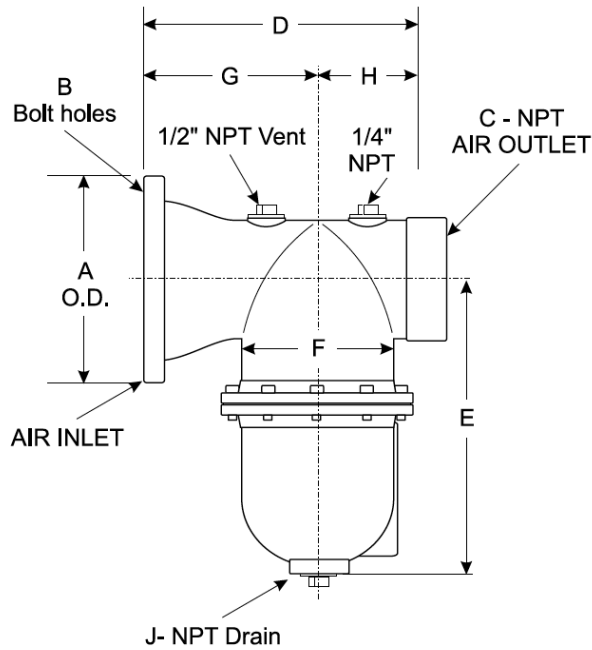

SIZES: 3 x 2 THRU 5 x 3

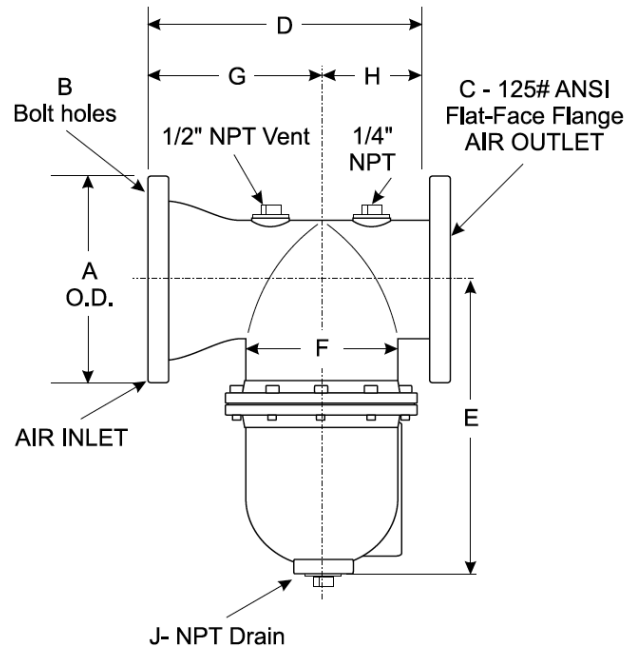

SIZES: 6 x 4 THRU 12 x 8

NOTE: 14x10 & 16x12 not shown

In/Out Size (in.)	Inlet A	N#	B-Bolt holes		Outlet C	D	E	F	G	H	J	Wgt. Lbs.
			Size	B.								
3x2	6 3/8"	8	5/8"	5 1/4"	2" NPT	9 1/4"	11 3/4"	5 7/8"	5 3/8"	3 7/8"	1"	65
4x2 1/2	7 3/8"	8	5/8"	6 1/4"	2 1/2" NPT	10 1/4"	13"	6 5/8"	5 3/4"	4 1/2"	1"	75
5x3	8 1/2"	12	5/8"	7 3/8"	3" NPT	11 3/4"	14 1/2"	7 3/4"	6 3/4"	5"	1"	115
6x4	9 1/2"	12	5/8"	8 3/8"	4" 125#	15"	16 1/4"	9 1/8"	8 1/2"	6 1/2"	1 1/4"	160
8x6	11 1/2"	12	5/8"	10 3/8"	6" 125#	17 1/2"	19 1/2"	11 1/4"	9 1/2"	8"	1 1/4"	240
10x6	13 3/4"	16	5/8"	12 5/8"	6" 125#	21"	24 3/4"	13 5/8"	11 3/4"	9 1/4"	1 1/2"	330
12x8	15 3/4"	16	5/8"	14 5/8"	8" 125#	26"	30"	16"	14"	12"	1 1/2"	510
14x10	17"	20	5/8"	15 7/8"	10" 125#	30"	37"	18"	15"	15"	2"	610
16x12	19"	20	5/8"	17 7/8"	12" 125#	38"	55"	24"	19"	19"	2"	935

Design - 150 P.S..G. @ 400°F. Consult factory for other designs.

Optional Separators & Traps Available

Alternative separators and traps are available from stock in 1-1/4" NPT to 4" NPT or flange sizes for both removable and fixed bundle aftercoolers.



TC Trap

Type "T" Separator



Type "TC" Separator
includes integral trap



Capacity Ratings of PLAC

The BASCO standard PLAC unit is designed with a removable tube bundle with either 3/8" or 5/8" tubes. Fabricated according to ASME code, they are designed to operate at 150 psi maximum. Units for operation up to 300 psi are available for specialized applications. For further information please contact your nearby API Heat Transfer Representative or the factory.

Application	Single Stage		Single Stage		Two Stage		Rotary		Multi-Stage		Multi-Stage		Multi-Stage	
	50 PSI		70-125 PSI		80-125 PSI		80-125 PSI		200 PSI		250 PSI		300 PSI	
Present Range	50 PSI		70-125 PSI		80-125 PSI		80-125 PSI		200 PSI		250 PSI		300 PSI	
Approach T Aftercooler Model	15°	10°	15°	10°	15°	10°	15°	10°	15°	10°	15°	10°	15°	10°
3BR03072	170	100	130	80	220	130	240	120	190	120	180	120	170	110
3BR04072	380	220	300	180	500	280	550	270	430	280	410	260	380	250
3BR05072	680	390	540	320	890	510	990	480	780	500	730	470	680	440
3BR06072	1180	670	920	540	1560	870	1730	830	1350	860	1270	810	1180	760
3BR08072	2270	1300	1780	1050	3000	1680	3340	1610	2600	1650	2440	1560	2270	1460
3BR10072	3890	2230	3050	1790	5130	2880	5710	2750	4450	2830	4180	2670	3890	2500
3BR12072	5930	3410	4650	2740	7830	4390	8720	4200	6800	4320	6370	4070	5940	3810
3BR14072	7370	4230	5780	3400	9720	5450	10830	5220	8440	5370	7920	5060	7380	4740
3BR16072	9930	5710	7800	4590	13120	7360	14610	7040	11390	7240	10680	6830	9960	6390
5BR03129	180	100	140	80	230	130	260	120	200	130	190	120	180	110
5BR04129	340	190	260	150	450	250	500	240	390	240	360	230	340	210
5BR05129	510	290	400	230	670	380	750	360	580	370	550	350	510	330
5BR06129	1090	610	850	490	1450	800	1620	760	1250	780	1170	740	1080	690
5BR08129	1990	1120	1550	900	2660	1460	2980	1390	2300	1440	2150	1350	2000	1260
5BR10129	3320	1870	2590	1500	4430	2440	4960	2330	3830	2400	3580	2250	3330	2110
5BR12129	5200	2940	4050	2350	6940	3820	7760	3640	6000	3750	5610	3530	5220	3300
5BR14129	6470	3650	5040	2920	8640	4750	9660	4530	7460	4670	6980	4390	6490	4100
5BR16129	8650	4880	6730	3900	11540	6340	12900	6060	9970	6240	9330	5870	8680	5490

Ratings in SCFM @ 14.7 PS.A & 60°F

Notes

Above capacities are based upon the following average conditions:

- Cooling water inlet = 75° F, Temperature rise = 20° F
- Tabulated capacities allow for condensing water vapor heat load. Initial suction conditions of 14.5 psi., 70° F and 60% relative humidity are assumed.
- Average air stream pressure drop (aftercooler and separator) will equal 2%-3% of line pressure.
- Inlet air temperature:
 Single stage (50 psi) = 325° F Single stage (70-125 psi) = 350° F Two stage (80-125 psi) = 250° F Rotary (80-125 psi) = 170° F
 Multi-stage (200 psi)* = 300° F
 Multi-stage (250 psi)* = 310° F
 Multi-stage (300 psi)* = 325° F

Standard Design Data

	Shell	Tube
Exchanger		
Design Pressure (PSI)	150	150
Design Temperature (°F)	300/20	400/20
Max/Min		
Separator		
Design Pressure (PSI)	150	150
Design Temperature (°F)	300/20	400/20
Max/Min		

Description

Plac/Pipeline Aftercooler
 3BR = 3/8" OD Bare Tube; Removable Bundle
 5BR = 5/8" OD Bare Tube; Removable Bundle

*Non-standard designs

PLAC 150# Pipeline Aftercooler

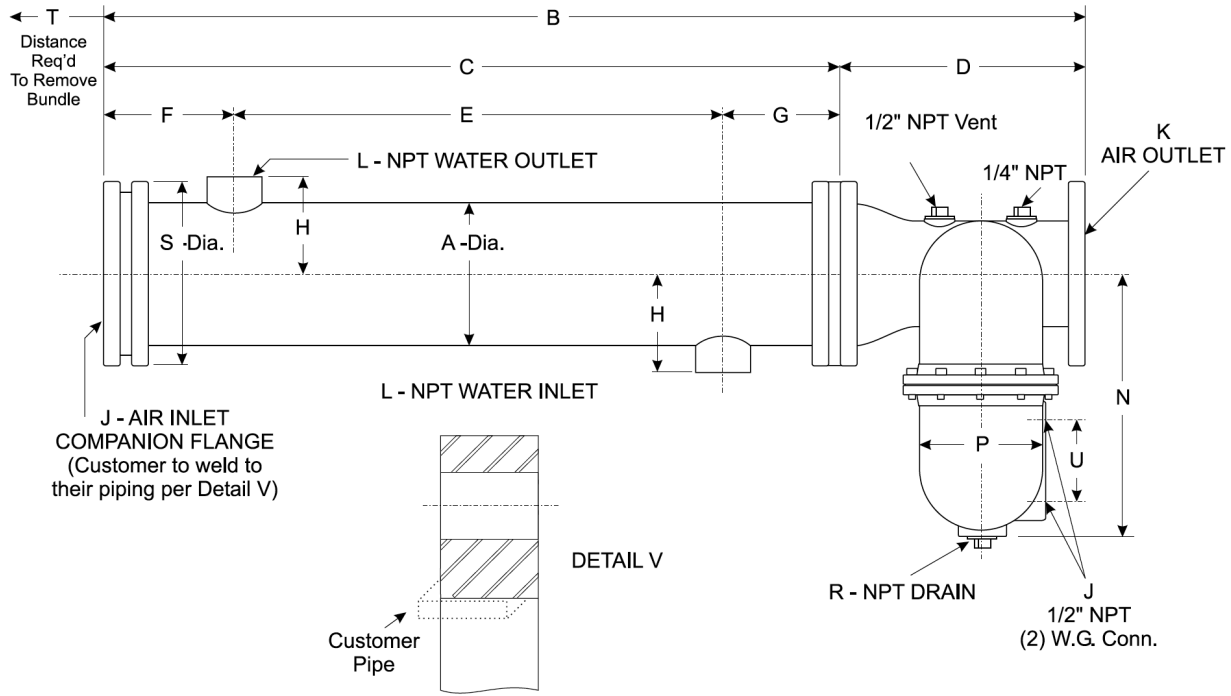

PLAC 3/8" O.D., x 6'0" Lg. Tubes/ASME Code Construction

Unit Size	A	B	C	D	E	F	G	H	J	K	L	N	P	R	S	T	U	Wgt. Lbs.
3	3 1/2"	6' 10"	6 3/4"	9 1/4"	5' 3"	5 3/16"	4 9/16"	2 5/8"	3 5/8"	2" NPT	1"	11 3/4"	5 7/8"	1"	6 3/8"	6' 6"	4 3/4"	120
4	4 1/2"	6' 11 1/16"	6 13/16"	10 1/4"	5' 3"	5 1/4"	4 9/16"	3 1/4"	4 5/8"	2 1/2" NPT	1"	13"	6 5/8"	1"	7 3/8"	6' 6"	4 3/4"	180
5	5 9/16"	7 9/16"	6 13/16"	11 3/4"	5' 3"	5 1/4"	4 9/16"	3 7/8"	5 11/16"	3" NPT	1 1/4"	14 1/2"	7 3/4"	1"	8 1/2"	6' 6"	4 3/4"	250
6	6 5/8"	7' 3 3/4"	6 3/4"	15"	5' 3"	5 3/16"	4 9/16"	4 7/16"	6 3/4"	4" 125# FF	1 1/4"	16 1/4"	9 1/8"	1 1/4"	9 1/2"	6' 6"	4 3/4"	340
8	8 5/8"	7' 6 3/8"	6 7/8"	17 1/2"	5' 3"	5 5/16"	4 9/16"	5 11/16"	8 3/4"	6" 125# FF	1 1/2"	19 1/2"	11 1/4"	1 1/4"	11 1/2"	6' 6"	4 3/4"	600
10	10 3/4"	7' 9 7/8"	6 7/8"	21"	5' 2"	5 13/16"	5 9/16"	6 7/8"	10 7/8"	6" 125# FF	2"	24 3/4"	13 5/8"	1 1/2"	13 3/4"	6' 6"	6"	840
12	12 3/4"	8' 3"	6' 1"	26"	5' 1"	6 7/16"	5 9/16"	8 1/8"	12 7/8"	8" 125# FF	3"	30"	16"	1 1/2"	15 3/4"	6' 6"	6"	1190
14	14"	8' 7 1/16"	6' 11/16"	30"	5' 0"	7"	6 1/16"	8 3/4"	14 1/8"	10" 150# RF	3"	37"	18"	2"	17"	6' 6"	7 7/8"	1400
16	16"	9' 3 1/4"	6' 1 1/4"	38"	5' 0"	7 1/4"	6"	9 7/8"	16 1/8"	12" 150# RF	3"	55"	24"	2"	19"	6' 6"	7 7/8"	2075

PLAC 5/8" O.D., x 10'9" Lg. Tubes

Unit Size	A	B	C	D	E	F	G	H	J	K	L	N	P	R	S	T	U	Wgt. Lbs.
3	3 1/2"	11' 7"	10' 9 3/4"	9 1/4"	10'	5 3/16"	4 9/16"	2 5/8"	3 5/8"	2" NPT	1"	11 3/4"	5 7/8"	1"	6 3/8"	11' 3"	4 3/4"	160
4	4 1/2"	11' 8 1/16"	10' 9 13/16"	10 1/4"	10'	5 1/4"	4 9/16"	3 1/4"	4 5/8"	2 1/2" NPT	1"	13"	6 7/8"	1"	7 3/8"	11' 3"	4 3/4"	260
5	5 9/16"	11' 9 9/16"	10' 9 13/16"	11 3/4"	10'	5 1/4"	4 9/16"	3 7/8"	5 11/16"	3" NPT	1 1/4"	14 1/2"	7 3/4"	1"	8 1/2"	11' 3"	4 3/4"	360
6	6 5/8"	12 3/4"	10' 9 3/4"	15"	10'	5 3/16"	4 9/16"	4 7/16"	6 3/4"	4" 125# FF	1 1/4"	16 1/4"	9 1/8"	1 1/4"	9 1/2"	11' 3"	4 3/4"	480
8	8 5/8"	12' 3 3/8"	10' 9 7/8"	17 1/2"	10'	5 5/16"	4 9/16"	5 11/16"	8 3/4"	6" 125# FF	1 1/2"	19 1/2"	11 1/4"	1 1/4"	11 1/2"	11' 3"	4 3/4"	890
10	10 3/4"	12' 6 7/8"	10' 9 7/8"	21"	9' 11"	5 13/16"	5 1/16"	6 7/8"	10 7/8"	6" 125# FF	2"	24 3/4"	13 5/8"	1 1/2"	13 3/4"	11' 3"	6"	1245
12	12 3/4"	13' 0"	10' 10"	26"	9' 10"	6 7/16"	5 1/16"	8 1/8"	12 7/8"	8" 125# FF	3"	30"	16"	1 1/2"	15 3/4"	11' 3"	6"	1760
14	14"	13' 4 1/16"	10' 10 1/16"	30"	9' 9"	7"	6 1/16"	8 3/4"	14 1/8"	10" 150# RF	3"	37"	18"	2"	17"	11' 3"	7 7/8"	2160
16	16"	14 1/4"	10' 10 1/4"	38"	9' 9"	7 1/4"	6"	9 7/8"	16 1/8"	12" 150# RF	3"	55"	24"	2"	19"	11' 3"	7 7/8"	2985

Use only certified drawings for construction.

Capacity Ratings of PLAC II

The BASCO standard PLAC II unit is a compact version of the PLAC. It utilizes specially contoured BASCOR® 3/8" or 5/8" tubes with enhanced surface. Fabricated according to ASME code, they are designed to operate at 150 psi maximum. Units for operation up to 300 psi* are available for specialized applications. For further information please contact your nearby API Heat Transfer Representative or the factory.

Application	Single Stage		Single Stage		Two Stage		Rotary		Multi-Stage		Multi-Stage		Multi-Stage	
Present Range	50 PSI		70-125 PSI		80-125 PSI		80-125 PSI		200 PSI		250 PSI		300 PSI	
Approach T Aftercooler Model	15°	10°	15°	10°	15°	10°	15°	10°	15°	10°	15°	10°	15°	10°
3CR03036	170	100	130	80	220	130	240	120	190	120	180	120	170	110
3CR04036	380	220	300	180	500	280	550	270	430	280	410	260	380	250
3BR05036	680	390	540	320	890	510	990	480	780	500	730	470	680	440
3CR06036	1180	670	920	540	1560	870	1730	830	1350	860	1270	810	1180	760
3CR08036	2270	1300	1780	1050	3000	1680	3340	1610	2600	1650	2440	1560	2270	1460
3CR10036	3890	2230	3050	1790	5130	2880	5710	2750	4450	2830	4180	2670	3890	2500
3CR12036	5930	3410	4650	2740	7830	4390	8720	4200	6800	4320	6370	4070	5940	3810
3CR14036	7370	4230	5780	3400	9720	5450	10830	5220	8440	5370	7920	5060	7380	4740
3CR16036	9930	5710	7800	4590	13120	7360	14610	7040	11390	7240	10680	6830	9960	6390
5CR03060	160	90	120	70	210	120	230	110	180	110	170	110	160	110
5CR04060	320	180	240	140	420	230	470	220	360	230	340	210	320	210
5CR05060	500	280	380	220	660	360	740	350	570	360	530	340	500	330
5CR06060	810	460	630	370	1080	590	1210	570	930	580	870	550	810	510
5CR08060	1620	910	1260	730	2160	1190	2410	1130	1870	1170	1750	1100	1620	1030
5CR10060	2660	1500	2060	1200	3540	1950	3960	1860	3060	1920	2860	1800	2660	1690
5CR12060	4140	2330	3220	1870	5520	3040	6170	2900	4770	2990	4460	2810	4150	2630
5CR14060	5220	2940	4060	2350	6960	3830	7780	3650	6010	3770	5620	3540	5230	3310
5CR16060	6980	3930	5420	3140	9300	5120	10400	4880	8040	5030	7510	4730	6990	4430

Ratings in SCFM @ 14.7 PS.A & 60°F

Notes

Above capacities are based upon the following average conditions:

- Cooling water inlet = 75° F, Temperature rise = 20° F
- Tabulated capacities allow for condensing water vapor heat load. Initial suction conditions of 14.5 psi., 70° F and 60% relative humidity are assumed.
- Average air stream pressure drop (aftercooler and separator) will equal 2%-3% of line pressure.
- Inlet air temperature:
 Single stage (50 psi) = 325° F
 Single stage (70-125 psi) = 350° F
 Two stage (80-125 psi) = 250° F
 Rotary (80-125 psi) = 170° F
 Multi-stage (200 psi)* = 300° F
 Multi-stage (250 psi)* = 310° F
 Multi-stage (300 psi)* = 325° F

*Non-standard designs

Standard Design Data

	Shell	Tube
Exchanger		
Design Pressure (PSI)	150	150
Design Temperature (°F)	300/20	400/20
Max/Min		
Separator		
Design Pressure (PSI)	150	150
Design Temperature (°F)	300/20	400/20
Max/Min		

Description

Plac/Pipeline Aftercooler

3CR = 3/8" OD Contoured Tubes; Removable Bundle

5CR = 5/8" OD Contoured Tubes; Removable Bundle

PLAC II 150# Pipeline Aftercooler

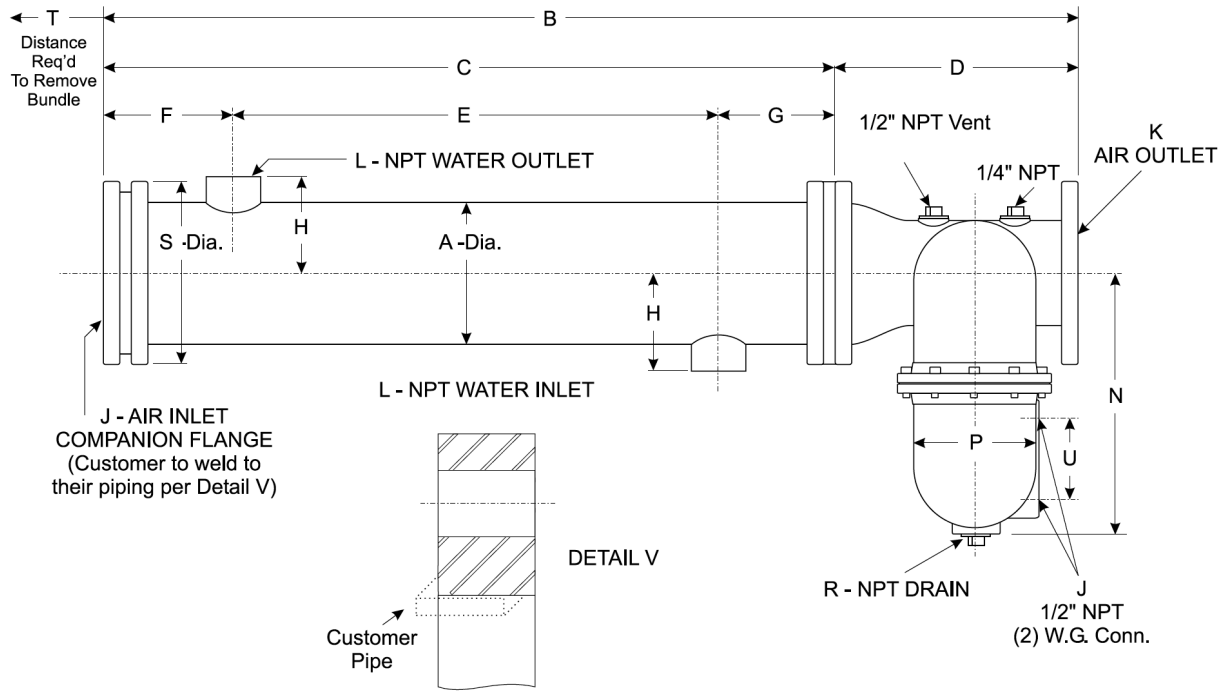

PLAC 3/8" O.D., x 3'0" Lg. Basco® Tubes/ASME Code Construction

Unit Size	A	B	C	D	E	F	G	H	J	K	L	N	P	R	S	T	U	Wgt. Lbs.
3	3 1/2"	3' 10"	3 3/4"	9 1/4"	2' 3"	5 3/16"	4 9/16"	2 5/8"	3 5/8"	2" NPT	1"	11 3/4"	5 7/8"	1"	6 3/8"	3' 6"	4 3/4"	90
4	4 1/2"	3' 11 1/16"	31 3/16"	10 1/4"	2' 3"	5 1/4"	4 9/16"	3 1/4"	4 5/8"	2 1/2" NPT	1"	13"	6 5/8"	1"	7 3/8"	3' 6"	4 3/4"	135
5	5 9/16"	4 9/16"	31 3/16"	11 3/4"	2' 3"	5 1/4"	4 9/16"	3 5/8"	5 11/16"	3" NPT	1 1/4"	14 1/2"	7 3/4"	1"	8 1/2"	3' 6"	4 3/4"	185
6	6 5/8"	4' 3 3/4"	3 3/4"	15"	2' 3"	5 3/16"	4 9/16"	4 7/8"	6 3/4"	4" 125# FF	1 1/4"	16 1/4"	9 1/8"	1 1/4"	9 1/2"	3' 6"	4 3/4"	250
8	8 5/8"	4' 6 3/8"	3 7/8"	17 1/2"	2' 3"	5 5/16"	4 9/16"	5 11/16"	8 3/4"	6" 125# FF	1 1/2"	19 1/2"	11 1/4"	1 1/4"	11 1/2"	3' 6"	4 3/4"	460
10	10 3/4"	4' 9 7/8"	3 7/8"	21"	2' 2"	5 13/16"	5 9/16"	6 7/8"	10 7/8"	6" 125# FF	2"	24 3/4"	13 5/8"	1 1/2"	13 3/4"	6' 6"	6"	840
12	12 3/4"	5' 3"	3' 1"	26"	2' 1"	6 7/16"	5 7/16"	8 1/8"	12 1/8"	8"-125# FF	3"	30"	16"	1 1/2"	15 3/4"	3' 6"	6"	900
14	14"	5' 7 1/16"	3' 1 1/16"	30"	2' 0"	7"	6 1/16"	8 3/4"	14 1/8"	10"-150# RF	3"	37"	18"	2"	17"	3' 6"	7 7/8"	1035
16	16"	6' 3 1/4"	3' 1 1/4"	38"	2' 0"	7 1/4"	6"	9 7/8"	16 1/8"	12"-150# RF	3"	55"	24"	2"	19"	3' 6"	7 7/8"	1620

PLAC 5/8" O.D., x 5'0" Lg. Basco® Tubes

Unit Size	A	B	C	D	E	F	G	H	J	K	L	N	P	R	S	T	U	Wgt. Lbs.
3	3 1/2"	5'-10"	5 3/4"	9 1/4"	4' 3"	5 3/16"	4 9/16"	2 5/8"	3 5/8"	2" NPT	1"	11 3/4"	5 7/8"	1"	6 3/8"	5' 6"	4 3/4"	100
4	4 1/2"	5' 11 1/16"	5 13/16"	10 1/4"	4' 3"	5 1/4"	4 9/16"	3 1/4"	4 5/8"	2 1/2" NPT	1"	13"	6 5/8"	1"	7 3/8"	5' 6"	4 3/4"	165
5	5 9/16"	6 9/16"	5 13/16"	11 3/4"	4' 3"	5 1/4"	4 9/16"	3 7/8"	5 11/16"	3" NPT	1 1/4"	14 1/2"	7 3/4"	1"	8 1/2"	5' 6"	4 3/4"	230
6	6 5/8"	6' 3 3/4"	5 3/4"	15"	4' 3"	5 3/16"	4 9/16"	4 7/8"	6 3/4"	4" 125# FF	1 1/4"	16 1/4"	9 1/8"	1 1/4"	9 1/2"	5' 6"	4 3/4"	295
8	8 5/8"	6' 6 3/8"	5 7/8"	17 1/2"	4' 3"	5 5/16"	4 9/16"	5 11/16"	8 3/4"	6" 125# FF	1 1/2"	19 1/2"	11 1/4"	1 1/4"	11 1/2"	5' 6"	4 3/4"	600
10	10 3/4"	6' 9 7/8"	5 7/8"	21"	4' 2"	5 13/16"	5 1/16"	6 7/8"	10 7/8"	6" 125# FF	2"	24 3/4"	13 5/8"	1 1/2"	13 3/4"	5' 6"	6"	815
12	12 3/4"	7' 3"	5' 1"	26"	4' 1"	6 7/16"	5 1/16"	8 1/8"	12 7/8"	8" 125# FF	3"	30"	16"	1 1/2"	15 3/4"	5' 6"	6"	1145
14	14"	7' 7 1/16"	5' 1 1/16"	30"	4'	7"	6 1/16"	8 3/4"	14 1/8"	10" 150# RF	3"	37"	18"	2"	17"	5' 6"	7 7/8"	1390
16	16"	8' 3 1/4"	5' 1 1/4"	38"	4'	7 1/4"	6"	9 7/8"	16 1/8"	12" 150# RF	3"	55"	24"	2"	19"	5' 6"	7 7/8"	2015

Use only certified drawings for construction.



API Heat Transfer, a family of high-performance brands 

High-performance heat transfer.

It's who we are and what we do. It's part of our 140-year heritage designing and delivering world-class heat transfer products for nearly every industry. It's bolstered by our worldwide network of manufacturing facilities that provide sales, service, and support. And it's ingrained in a process that has helped customers around the world for nearly a century and a half.

When you work with us, you'll find the performance of our technologies sets the bar for heat transfer products, and our relentless drive to find and create custom heat transfer solutions to meet any industry challenge sets us apart.

See how our performance can improve yours.

Contact your API Heat Transfer sales rep or visit apiheattransfer.com today.

USA

Buffalo Facility

2777 Walden Avenue
Buffalo, NY 14225, USA
+1.716.684.6700

Iron Ridge Facility

1025 Industrial Road
Iron Ridge, WI 53035, USA
+1.920.387.4200

Franklin Facility

4700 Ironwood Drive
Franklin, WI 53132, USA
+1.414.761.4500

Racine Facility

5215 21st Street
Racine, WI 53406, USA
+1.262.554.8330

GERMANY

Bretten Facility

Langenmorgen 4
75015 Bretten, Germany
+49.7252.53.0

Dortmund Facility

Breienbachstrasse 87
44357 Dortmund, Germany
+49.231.9920.119

CHINA

Suzhou Facilities Building 1

156 Qingqiu Street, 3rd District
Suzhou Industrial Park
Suzhou, Jiangsu 215126, China
+86.512.8816.8000

Building 2

126 Qingqiu Street, 3rd District
Suzhou Industrial Park
Suzhou, Jiangsu 215126, China
+86.512.8816.8000

Shanghai

Gubei 1699 Commercial Plaza
Room 905-1
1699 Gubei Road
Minhang District
Shanghai 201103, China
+86. 21.5426.2525

